

Clariflex®

STRONG-ARM



COMPACT PARTS BENDERS

MODEL NO: CCB1B & CCB2B

PART NO: 7630083 & 7630084

OPERATION INSTRUCTIONS

ORIGINAL INSTRUCTIONS

GC0221 rev -2

INTRODUCTION

Thank you for purchasing this CLARKE product. The compact metal parts bender allows you to economically make a variety of bends in flat, square or solid round stock. These instructions provide basic information on using the bender, plus step-by-step examples of how to bend stock to make several common products. We urge you to read the complete Operation section before trying to use the bender.

Before attempting to use this product, please read this manual thoroughly and follow the instructions carefully. In doing so you will ensure the safety of yourself and that of others around you and you can look forward to your purchase giving you long and satisfactory service.

GUARANTEE

This product is guaranteed against faulty manufacture for a period of 12 months from the date of purchase. Please keep your receipt which will be required as proof of purchase.

This guarantee is invalid if the product is found to have been abused or tampered with in any way, or not used for the purpose for which it was intended.

Faulty goods should be returned to their place of purchase, no product can be returned to us without prior permission.

This guarantee does not effect your statutory rights.

SAFETY PRECAUTIONS



WARNING: THE USER MUST FOLLOW ALL INSTRUCTIONS WITHIN THIS INSTRUCTION BOOKLET

To protect against serious injury, use common sense and observe the following precautions when using this product. Clarke International is not responsible for misuse of the equipment.

- ALWAYS secure the metal bender to the floor or bench before use.
- ALWAYS study these instructions before operating and pay close attention to all warnings.
- ALWAYS keep the work area free of obstructions.

- ALWAYS wear safety goggles when bending parts and when grinding or sanding them.
- ALWAYS be sure that enough material extends beyond the stop block and forming die when making bends, to be sure the material does not come free and allow the handle to release suddenly.
- ALWAYS insert the hinge pins fully before making bends.
- NEVER try to bend material other than hot-rolled mild steel.
- NEVER try to bend flat material larger than 5 16 x 2 in or square or solid round material larger than 5 8 in. (EXCEPTION: Rebar that is 1/2-in. diameter may be bent around the 3" die only).
- NEVER bend round stock when using the sharp-angle-bend attachment. Use only flat, hot-rolled, mild steel up to 3/16 x 2" or 1/4 x 1-1/4" with this attachment.
- NEVER try to bend material that is more than 1/ 4" thick around the centre pin (instead, use the 1" die on the pin).
- NEVER modify the metal bender or use a handle extension arm other than the one provided.

INDEX

Assembly	4
Basic Operations	5
Using the Stop Block	7
Using the Sharp-Angle-Bend Attachment	9
Examples	
Bending Handles	10
Bending Tube Clamps	12
Bending Anchor Bolts and U-Bolts	15
Bending Letters for Signs	19
Parts List & Diagram	46

ASSEMBLY

1. To attach the ring assembly to the stand (refer to the illustration opposite):
 - a. Attach the loop end of the ring assembly to the stand. Use the long bolt, flat washer, thick spacer (inside the loop), thin spacer, lock washer, and lock nut.
 - b. Attach the ring end to the stand with the two flat-head bolts, using thin spacers, flat washer, lock washers, and lock nuts.
2. Insert the loop end of the handle inside the loop of the ring assembly, and secure it by inserting one of the two longer hitch pins.
3. Remove the 'R' clip from the handle pin then remove the pin from the handle. Pull out the extension arm, install the pin in the outer hole, and reinstall the 'R' clip.
4. Set the bender in the position where you intend it to be used. Rotate the handle as far as it will go in both directions, to be sure there will be no obstructions when bending.
5. Attach the bender's base securely to the floor.

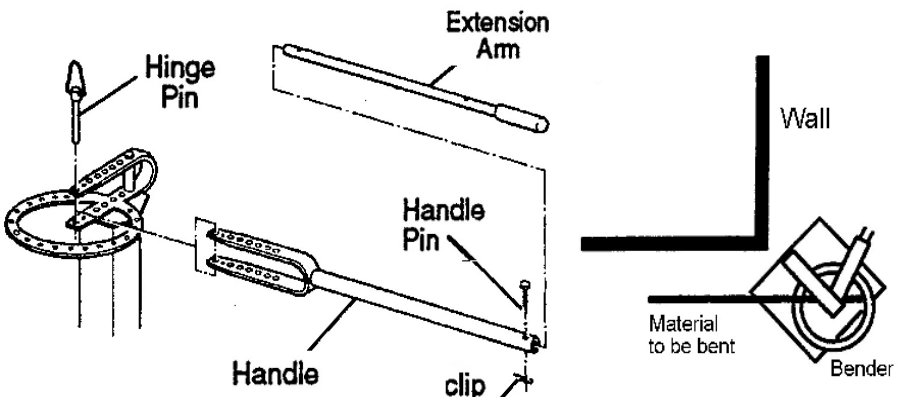
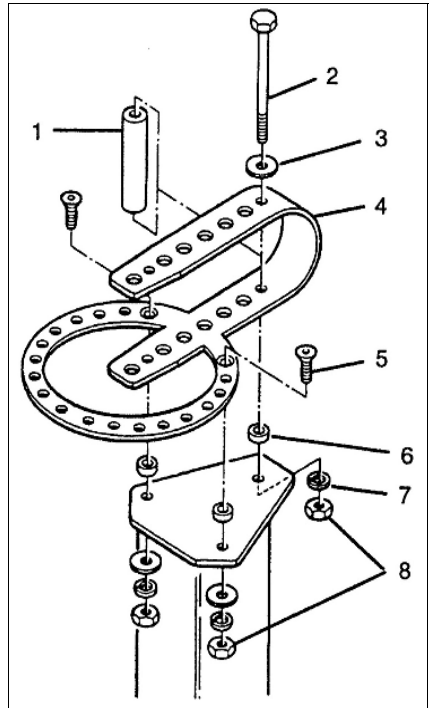

BASIC OPERATION

Most of this manual is devoted to showing you how to create basic shapes. Other than these specific instructions, setting up the bender to form your particular shape will involve a certain amount of trial-and-error.

You will notice some differences in operation depending on whether you are forming the piece around a die, or whether you are making a sharp-angle bend in the piece. However, in general you will:

1. Determine the appropriate material and size for the part(s) to be made.
2. Determine the appropriate dies to install on the centre pin and/or the pin installed in the handle, and determine the appropriate hole for attaching the handle to the ring assembly's loop.
3. Install the stop block or the sharp-angle-bend attachment, as appropriate. Install the block support. If the stop block is used, orient it properly. Refer to pages 4 and 5 for more information on the stop block and the sharp-angle-bend attachment.
4. Insert the blank stock into the bender, and position it properly for the first bend.
5. Make the first bend. Re-check the angle and location before continuing.
6. Make any additional bends in the same way. In some cases, you may have to remove the piece from the bender and turn it end-for-end or upside-down.

HOLE IDENTIFICATION

In the examples shown in this manual, the holes in the loop and those in the handle are identified by a number. Refer to the illustration at right.

MEASURING BEND ANGLES

When accuracy is required, you will need a suitable device for measuring the bend angles.

FIXED AND ADJUSTABLE STOPS

If you are making multiple parts with the same bend angle, using the same setup (dies and hole locations), the operation will be speeded up by installing either the fixed or adjustable stop in the appropriate hole in the ring assembly.

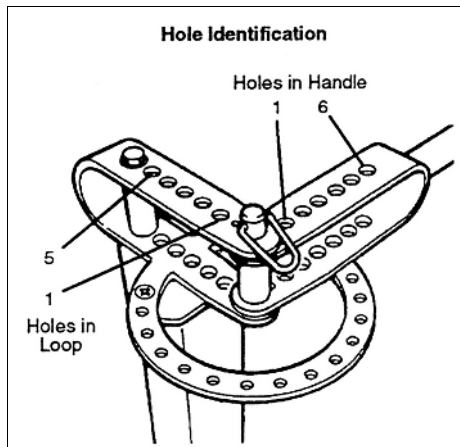

After determining the handle rotation, insert the fixed stop into the next open hole and use as a guide for bending additional parts.

When greater precision is required, attach the adjustable stop as accurately as you can at the limit of handle rotation. Make a test part with scrap material, and reposition the adjustable stop as necessary. Tighten bolt and nut securely before bending production parts.

NOTE: If precise dimension are required, start by making a test part using scrap material of the same thickness. Readjust the setup as necessary.

NOTE: Once you determine the dimensions, die size(s), holes, and bending sequence for a part, write down the information for future reference.

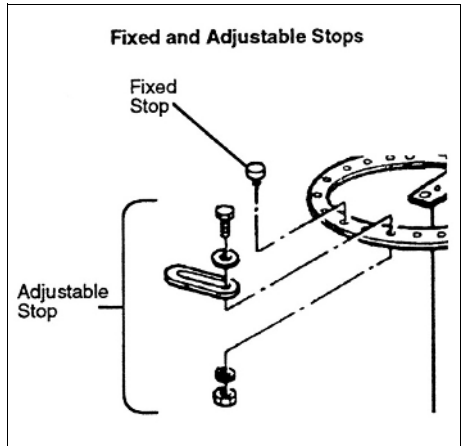

USING THE STOP BLOCK

IMPORTANT: Read page 4 before you proceed to this section.

THE PURPOSE OF THE STOP BLOCK

The stop block prevents the material from rotating while a forming die in the handle bends the material around either the centre pin or another die that has been installed on the centre pin.

When you are bending material, the stop block will be located (using a hitch pin) at one of the five large holes in the middle of the ring assembly's loop. (The large hole at the open end of the loop is for the centre pin.) You will have to determine by trial which hole you will use, depending on the thickness of the material being bent, the size of the centre-pin die, and the orientation of the stop block.

POSITIONING THE STOP BLOCK

The stop block can be placed in several positions by rotating it on the hinge pin or by turning it upside down and rotating it on the pin. However, only four of the possible positions are used when bending. Throughout this manual, those four positions are identified by a number (refer to the illustration at right).

CAUTION: ALWAYS POSITION THE STOP BLOCK OFF-CENTRE TO THE RIGHT—NO MATTER WHICH FACE IS USED AGAINST THE MATERIAL. IF POSITIONED OFF-CENTRE TO THE LEFT, THE BLOCK WILL TURN AND THE MATERIAL WILL SLIP IN THE BENDER.

To position the stop block (that is, to select the proper orientation and the proper hole in the loop):

1. Connect the handle to the centre pin of the loop, with the appropriate die installed on the centre pin.

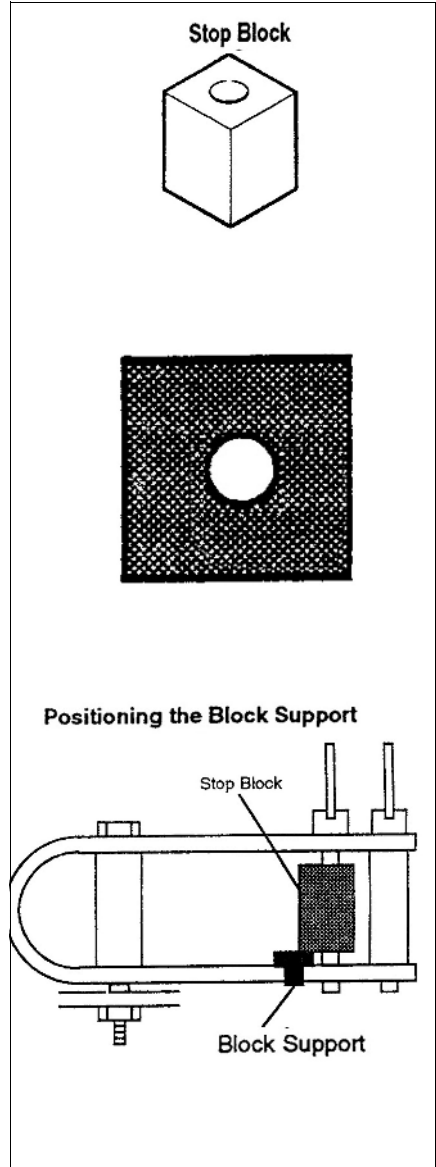

2. Install the appropriate die at the appropriate hole in the handle.
3. Inset a piece of the material to be formed. With the handle all the way back (anticlockwise), install the stop block in the orientation that places it as close to the centre pin as possible.

IMPORTANT: Always use the loop hole that places the stop block as close to the centre pin or die as possible, while leaving space for the material to be inserted.

If there is too much space between the stop block and the centre pin or die, turn the block to a different orientation or move the block one hole closer to the centre.

POSITIONING THE BLOCK SUPPORT

The block support must be located under the stop block as shown, to keep the block centered vertically in the loop.

Install the support in the appropriate loop hole where it will support the stop block but not interfere with inserting the hitch pin all the way through the block hole and the lower hole in the loop.

CLAMPING

If the stop block is positioned correctly, the material will normally not have to be clamped in the bender. However, when you are making special bends or need precise dimensions, it is helpful to clamp the material against the stop block using a vice-grip pliers as shown at right.

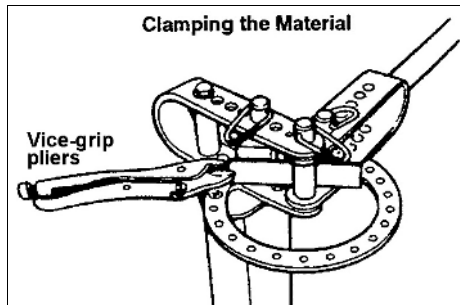

USING THE SHARP-ANGLE-BEND ATTACHMENT

PURPOSE OF THE ATTACHMENT

The sharp-angle-bend attachment is used instead of the stop block when you make a right-angle bend or other sharp bend in flat material.

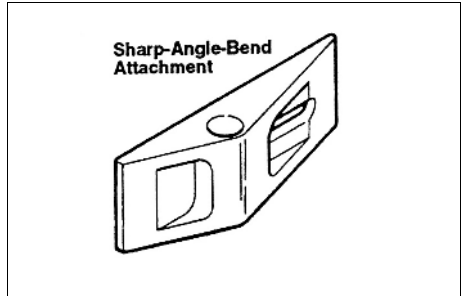

POSITIONING THE ATTACHMENT

In contrast to the stop block, the sharp-angle bend attachment has only one correct orientation—as shown at right, and with the hinge pin in the #2 hole in the loop.

POSITIONING THE BLOCK SUPPORT

The block support must be located under the sharp-angle-bend attachments, to keep the attachment centered vertically in the loop. (Compare the illustration on page 6 with the stop block.)

Install the support in the #3 loop hole, so it will support the attachment but not interfere with inserting the hitch pin all the way through the attachment's hole and the lower hole in the loop.

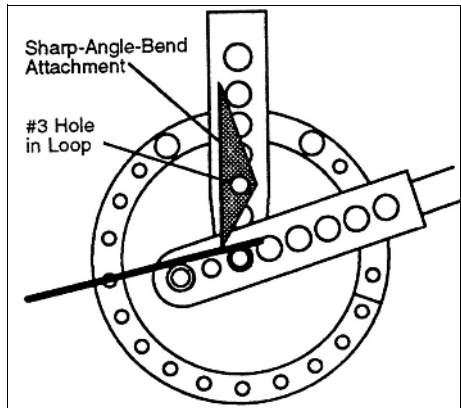

CLAMPING

The material should not need to be clamped when using the sharp-angle-bend attachment.

BENDING THE MATERIAL

Make thin chalk marks on the flat material to show where you want to make the bends. For an example, see page 10.

Insert the material into the bender so that half the width of the chalk mark shows and the other half is covered by the bending edge of the attachment.

If you are making two right-angle bends on the same side of the material, space their chalk marks about 1/8" further apart than the desired inside dimension after the bend.

EXAMPLE: BENDING HANDLES

HANDLES FROM ROUND STOCK

To make a typical handle, using a 9in. length of 3/8in. round stock and two pieces of flat stock:

NOTE: To make other sizes of handles, experiment to find the appropriate die sizes and stop block orientation.

1. With a long hinge pin, attach the handle and ring loops at their centre-pin holes. Install a 1in. die on the centre pin. With the short hinge pin, install a 2 in. die in the handle (#2 hole).
2. With a long hinge pin, install the stop block (oriented as in A).
3. Insert the round stock into the Bender so that it extends 2" beyond the centre-pin die (see B), and make the first bend to 90°.
4. Turn the part end-for-end, position it as in C, and make the second 90° bend. Remove the stock from the bender.
5. Drill 5/8" holes in the flat stock & insert the handle halfway through the holes

Always drill the holes the same size as the diameter of the handle stock.

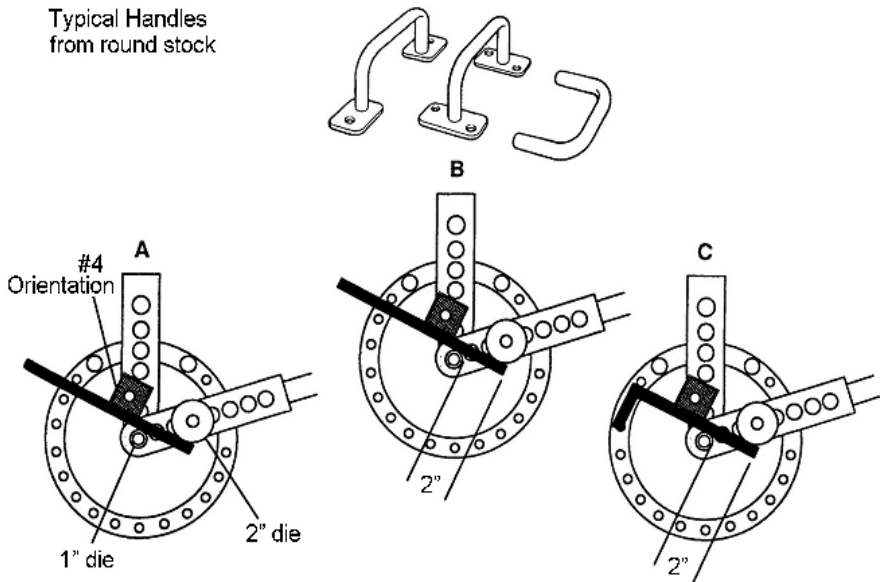

6. Weld the flat stock pieces in place from the back side. If any weld material extends below the surface of the flat plate, grind it flush.

HANDLES FROM FLAT STOCK

To make a typical handle, using a 9" length of 3/16" x 1" hot-rolled flat stock:

NOTE: To make other sizes of handles, experiment to find the appropriate bend locations.

1. Install the sharp-angle-bend attachment.
2. Place chalk marks on the material as shown under "Bend Sequence." the #1 and #2 marks are on one face of the material and the #3 and #4 marks are on the opposite face.
3. Insert the flat stock into the bender to the #1 mark as in A) and make a 90° bend. Check the angle before continuing.
4. Set the adjustable stop so each bend will be 90°.
5. Turn the stock end-for-end. Insert it to the #2 mark (as in B) and make a 90° bend.
6. Turn the stock over front-to-back. Insert it to the #3 mark (as in C) and make a 90° bend.
7. Turn the stock end-for-end. Insert it to the #4 mark (as in D) and make a 90° bend.
8. Grind and sand all sharp corners.

Typical handle from flat stock

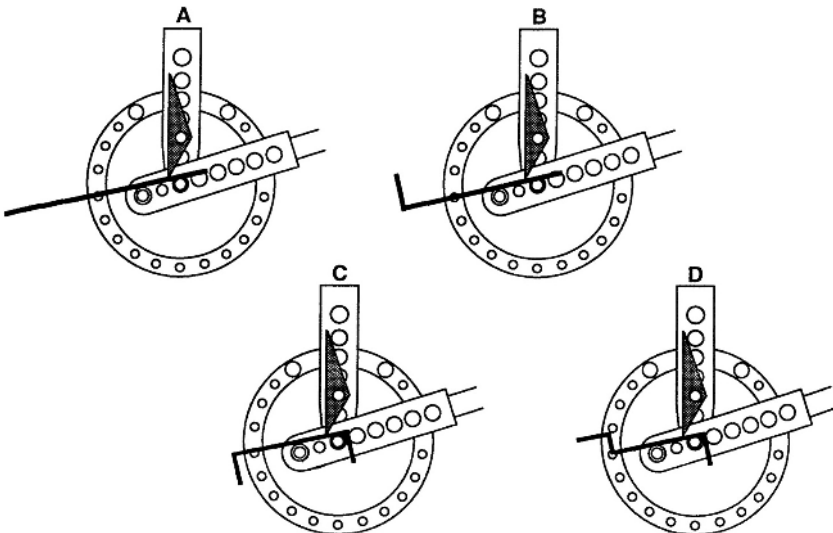

EXAMPLE: BENDING TUBE CLAMPS

SINGLE-TUBE CLAMP

To make a 1" I.D. tube clamp (for clamping 1" O.D. tubing), using a 4½" length of 3/16" x 1" hot-rolled flat stock:

NOTE: *To make other sizes of clamps, experiment to find the appropriate die sizes and stop block orientation.*

1. With a long hinge pin, attach the handle and ring loops at their centre-pin holes. Install a 1" die on the centre pin.
2. With the short hinge pin, install a 1½-in. die in the handle (#2 hole).
3. With a long hinge pin, install the stop block (oriented as in A below).
4. Insert the flat stock into the bender so that it extends 1½-in. beyond the centre-pin die (as in B below).
5. Clamp the stock against the stop block using a vice-grip pliers, to prevent the stock from slipping.
6. Make the first bend by pulling the handle around until the handle die runs off the end of the piece.
7. Remove the stop block and the two dies. Change the handle connection, and install the sharp-angle-bend attachment (as in C below).
8. Insert the stop pin into the 6th hole of the ring (counting clockwise from the closed end of the loop).

TYPICAL TUBE CLAMPS

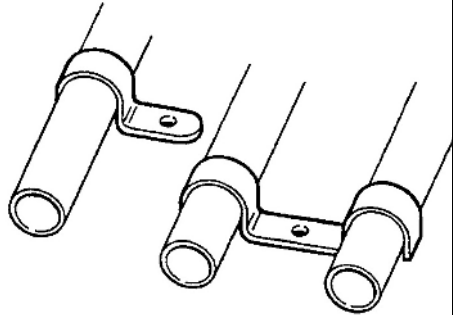

STOCK REQUIRED (for this example)

One 4½-in. length of 3/16-in. x 1-in. hot-rolled flat stock

9. Make the second bend by pulling the handle until it is about 1/8" from the stop pin.

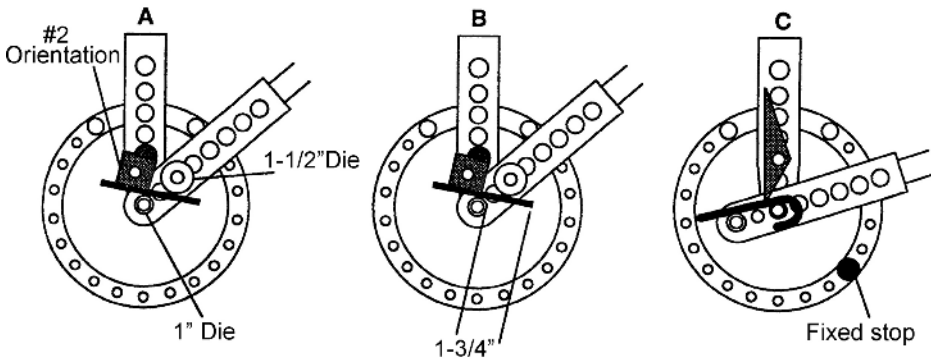

EXAMPLE: BENDING DOUBLE TUBE CLAMPS

DOUBLE-TUBE CLAMP

To make a 1" I.D. tube clamp (for clamping two lengths of 1" O.D. tubing), using a 4 1/2" length of 3/16" x 1" hot-rolled flat stock:

NOTE: To make other sizes of clamps, experiment to find the appropriate die sizes and stop block orientation.

1. With a long hinge pin, attach the handle and ring loops at their centre-pin holes. Install a 1" die on the centre pin.
2. With the short hinge pin, install a 1 1/2" die in the handle #2 hole).
3. With a long hinge pin, install the stop block (oriented as in A).
4. Insert the flat stock into the bender so that it extends 1-3/4" beyond the centre-pin die (as in B).

5. Make the first bend by pulling the handle around until the handle die runs off the end of the piece.
6. Reverse the part end-for-end. Insert it into the Bender so that it extends 1-3/4" beyond the centre-pin die (as in C).
7. Make the second bend by pulling the handle around until the handle die runs off the end of the piece.
8. Remove the stop block, and install the sharp-angle-bend attachment.
9. You will have to temporarily remove the centre pin to insert the piece into the bender. Slide the piece as far left as possible, against the centre pin (as in D).
10. Make the third bend by pulling the handle until it is about 1/8" from the stop pin.
11. Reverse the part end-for-end. Slide the piece as far left as possible, against the centre pin (as in E). You will again have to temporarily remove the centre pin to insert the piece into the bender.
12. Make the fourth bend by pulling the handle until it is about 1/8" from the stop pin.

STOCK REQUIRED (for this example)

One 6 1/2-in. length of 3/16-in. x 1-in. hot-rolled flat stock

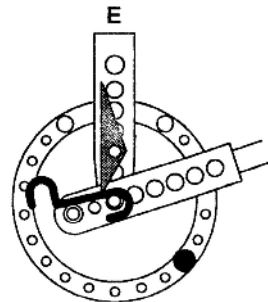
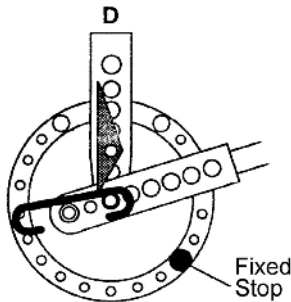
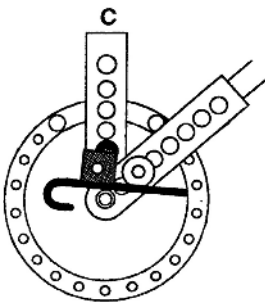
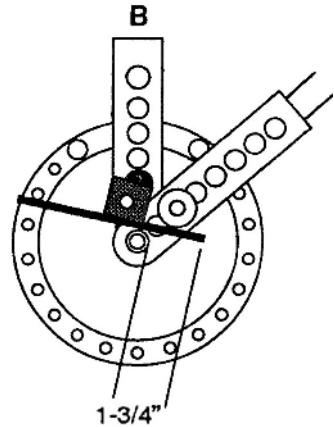
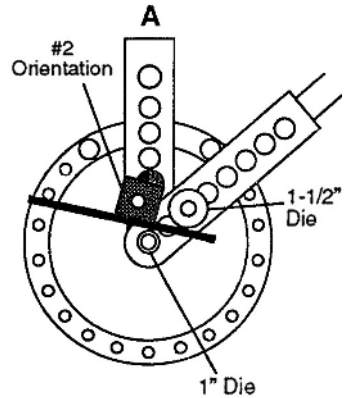

BENDING ANCHOR BOLTS AND U-BOLTS

ANCHOR BOLTS

To make a 10" long anchor bolt shown, from a 12¼" blank:

NOTE: To make another length bolt, just use a shorter or longer blank, or, change the dimension given in Step 3 below (being sure that enough material is caught by the block).

1. With a long hinge pin, attach the handle and ring loops at their centre pin holes. Install a 1" die on the centre pin.
2. With the short hinge pin, install a 2" die in the handle #2 hole).
3. With a long hinge pin, install the stop block. Orientate the block appropriately for the diameter of the u-bolt blank:

#2 orientation for 3/8" or 1/2" bolts;

#4 orientation for 5/8" bolts

4. Insert the bolt blank into the bender so that the un-threaded end extends beyond the stop block:

- 1/2" for 3/8" bolts;
- 5/8" for 1/2" bolts;
- 3/4" for 5/8" bolts.

5. Pull the handle around until the bolt shaft is 90° from the anchor.

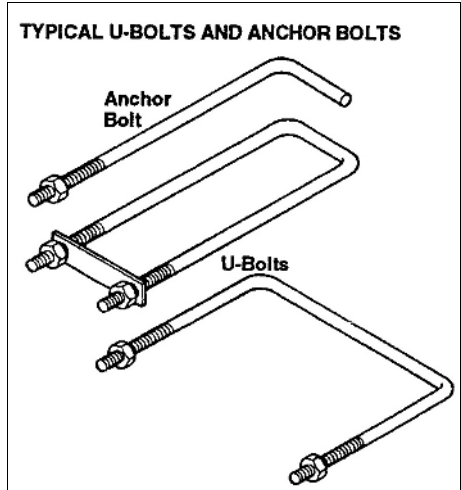

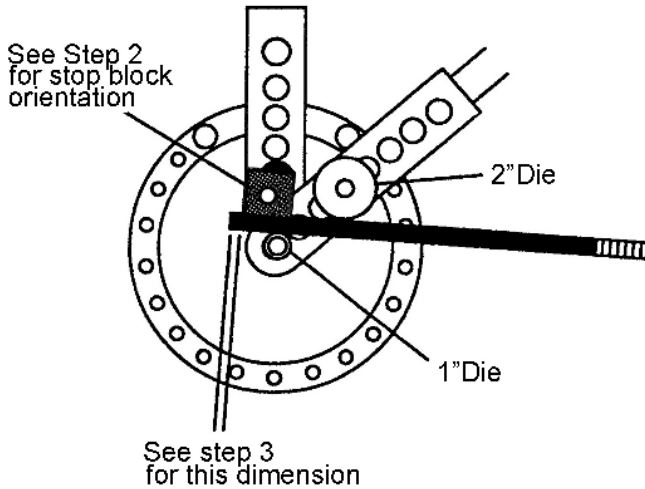

U-BOLTS

The tables on pages 18 and 19 show the appropriate setup for making U-bolts in typical finished lengths and bend radiuses, from common diameters of round stock.

The illustration below shows the setup for making a U-bolt that is 3½" long and 2" I.D., using 5/8" diameter stock. For other sizes, adjust the die sizes, stop block orientation, etc., as shown in the tables.

LENGTH

For longer U-bolts, add twice the additional length desired to the "blank length" indicated (for example, to make a U-bolt that is 1" longer, add 2" to the blank length).

BEND RADIUS

Eight bend radiuses are possible—by selecting from the seven forming dies, or by using centre pin without a die. However to avoid bending the centre pin, always use a forming die with round stock larger than 3/8" diameter.

NOTES

- Because blank stock may vary slightly in content or size, we recommend making a test bend using unthreaded stock before you make a quantity of U-bolts.
- Keep a record of die sizes, die positions, and other measurements for future reference.

Typical Setup for Bending U-Bolts from Round Stock

(see tables
for specific information)

See page 5 for
Hole No. identification.

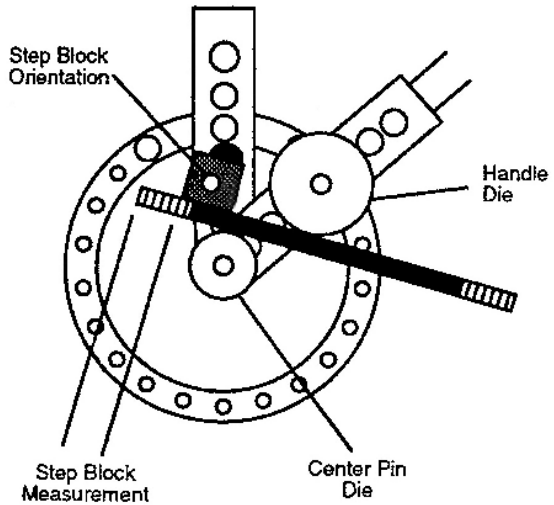

BENDING U-BOLTS FROM 1/4" ROUND STOCK

FINISHED SIZE		SETUP FOR BENDING						
Length	I.D.	Blank Length	Loop Hole No	Stop Block Orientation	Stop Block meas't	Centre Pin Die	Handle Die	Handle Hole No
2"	1"	5"	1	2	Flush	1"	2"	2
2 1/4"	1 1/4"	5 1/4"	1	2	1/4"	1 1/4"	2"	2
2 1/2"	1 1/2"	6 3/8"	1	1	3/8"	1 1/2"	2"	2
3"	1 3/4"	7 1/2"	2	4	1/4"	1 1/4"	2"	2
3 1/2"	2"	8 5/8"	2	4	7/8"	2"	1 3/4"	2

BENDING U-BOLTS FROM 1/4" ROUND STOCK

FINISHED SIZE		SETUP FOR BENDING						
Length	I.D.	Blank Length	Loop Hole No	Stop Block Orientation	Stop Block meas't	Centre Pin Die	Handle Die	Handle Hole No
2½"	1¼"	6¼"	1	1	5/16"	1¼"	2"	2
3"	1½"	7¾"	2	4	¼"	1½"	2"	2
3"	1¾"	7⅝"	2	4	⅜"	1¾"	2"	2
3½"	2"	8¾"	2	4	15/16"	2"	2"	2

BENDING U-BOLTS FROM 3/8" ROUND STOCK

FINISHED SIZE		SETUP FOR BENDING						
Length	I.D.	Blank Length	Loop Hole No	Stop Block Orientation	Stop Block meas't	Centre Pin Die	Handle Die	Handle Hole No
2½"	1¼"	6-½"	1	1	⅝"	1¼"	2"	2
3"	1½"	7-½"	2	4	7/16"	1½"	3"	2
3"	1¾"	7-¾"	2	4	9/16"	1¾"	3"	2
3"	2"	8"	2	3	⅛"	2"	2"	2

BENDING U-BOLTS FROM 1/2" ROUND STOCK

FINISHED SIZE		SETUP FOR BENDING						
Length	I.D.	Blank Length	Loop Hole No	Stop Block Orientation	Stop Block meas't	Centre Pin Die	Handle Die	Handle Hole No
2¾"	1½"	7¼"	2	4	7/16"	1½"	3"	3
3"	1¾"	8"	2	4	5/16"	1¾"	2"	3
3¼"	2"	8¾"	2	3	¾"	2"	2½"	3
4"	2½"	10⅝"	2	2	1"	2½"	2"	3
4½"	3"	11⅝"	3	4	1"	3"	2"	3

BENDING U-BOLTS FROM 5/8" ROUND STOCK

FINISHED SIZE		SETUP FOR BENDING						
Length	I.D.	Blank Length	Loop Hole No	Stop Block Orientation	Stop Block meas't	Centre Pin Die	Handle Die	Handle Hole No
3½"	2"	9¾"	2	2	1"	2"	3"	3
2½"	2½"	11½"	2	1	1⅝"	2½"	2"	3
5"	3"	12¾"	3	4	1⅞"	3"	2"	3

BENDING LETTERS FOR SIGNS

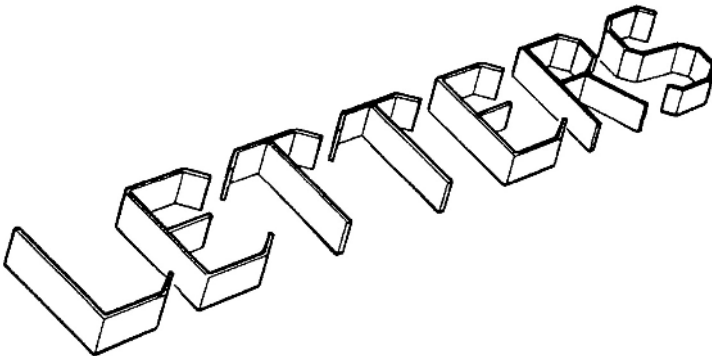

The following pages show how to make all 26 letters of the alphabet in a typical style. Using the procedure that is shown on these pages results in letters (from 3/16" flat stock) which are:

- 6" high
- 2" wide (deep)

NOTES

- Use **only** hot-rolled mild steel for forming the letters.
- Follow the bending steps exactly, and in the sequence given. This is especially important for the letter "S", which is the most difficult to form.

- To avoid wasting material, practice some of the letters using 316" stock that is only 1/2" wide before you attempt the finished version.
- If you have two or more identical letters, make all of them before proceeding to a different letter.

LETTER A

STOCK REQUIRED

- 3/16" stock; 2" max. width
- One 14" blank
- One 3-1/2" blank

BEND SEQUENCE

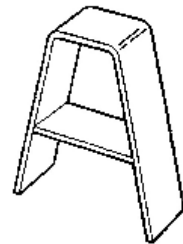
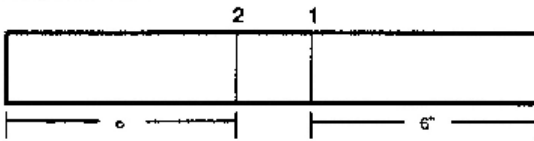

SETUP

Make chalk marks on the 14" blank as shown on the "Bend Sequence."

BEND NO. 1

Insert the stock into the Bender to the #1 chalk mark (as in A), and bend it to 76°. Re-check the angle before you go on to the second bend.

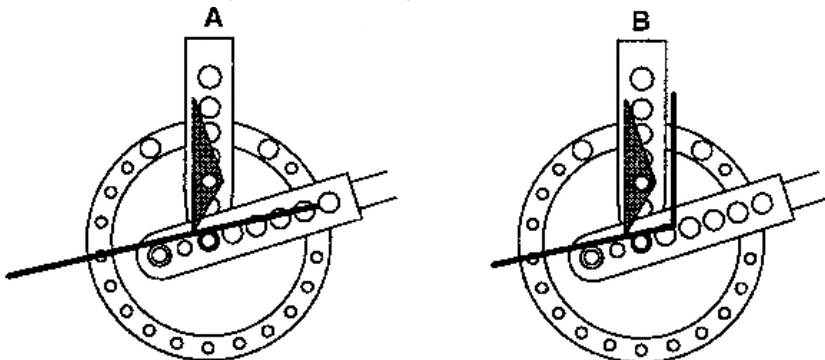

BEND NO. 2

Slide the stock to the #2 chalk mark (as in B), and bend it to 76°. Re-check the angle.

To remove the part from the Bender, remove the pin that holds the sharp-angle-bend attachment.

FINISHING

Tack-weld the 3-1/2" insert piece between the legs of the "A," parallel to the top edge. Grind and sand all sharp corners.

LETTER B

STOCK REQUIRED

- 3/16" stock; 2" max. Width

SETUP

Make chalk marks on the two 8-7/8" blanks as shown on the "Bend Sequence."

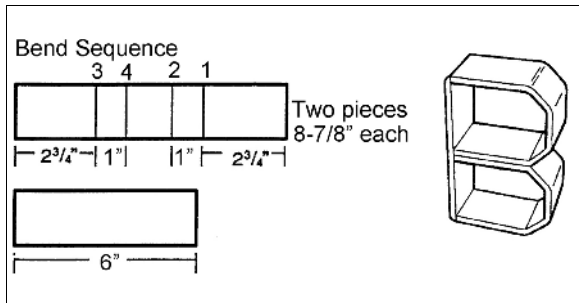

BEND NO. 1

Insert one of the blanks into the Bender to the #1 chalk mark (as in A), and bend it to 45°. Re-check the angle before you go on to the second bend.

Chalk-mark the ring, or set a stop, for ease of repeating the 45° bend.

BEND NO. 2

Slide the stock to the #2 chalk mark (as in B), and bend it to 45°. Re-check the angle.

BEND NO. 3

Reverse the stock end-for-end. Slide it to the #3 chalk mark (as in C), and bend it to 45°. Re-check the angle.

BEND NO. 4

Again reverse the stock end-for-end. Move it to the #4 chalk mark (as in D), and bend it to 45°. Re-check the angle.

To remove the part from the Bender, remove the pin that holds the sharp-angle-bend attachment.

FINISHING

Tack-weld the two loops together. Tack-weld the 6 in. piece to form the back of the letter "B". Grind and sand all sharp corners.

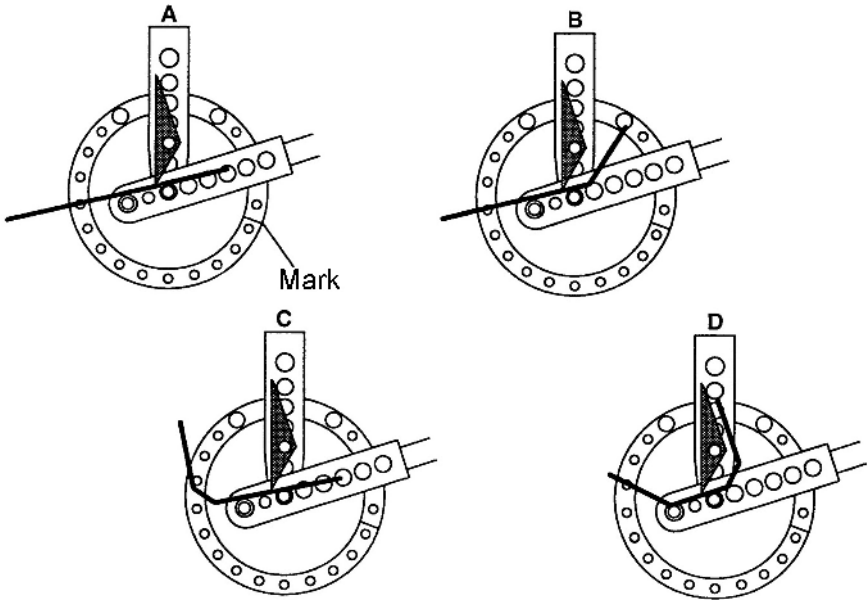

LETTER C

Bend sequence

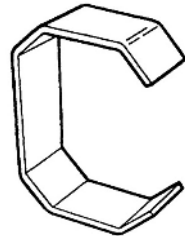
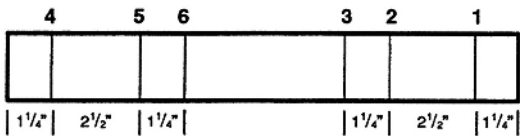

STOCK REQUIRED

- $3/16"$ stock; 2" max. Width (1x 14-in blank)

SETUP

Make chalk marks on the 14" blank as shown on the "Bend Sequence."

BEND NO. 1

Insert the stock into the Bender to the #1 chalk mark (as in A), and bend it to 45°. Re-check the angle before you go on to the second bend.

BEND NO. 2

Slide the stock to the #2 chalk mark (as in B), and bend it to 45°. Re-check the angle.

BEND NO. 3

Slide the stock to the #3 chalk mark (as in C), and bend it to 45°. Re-check the angle.

FINISHING

Reverse the stock end-for-end. Slide it to the #4 chalk mark (as in D), and bend it to 45°. Re-check the angle.

BEND NO. 4

Slide the stock to the #5 chalk mark (as in E), and bend it to 45°. Re-check the angle.

BEND NO. 65

Slide the stock to the #6 chalk mark (as in F), and bend it to 45°. Re-check the angle.

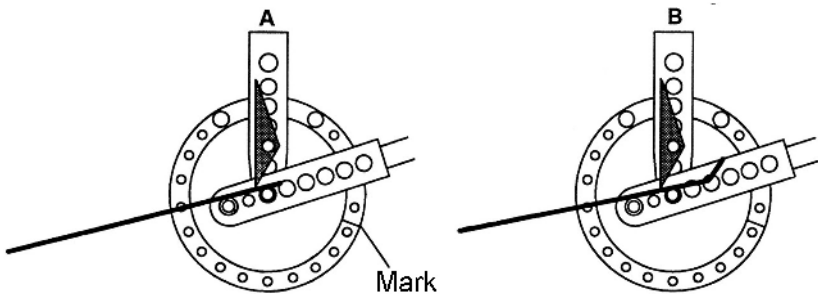

To remove the part from the bender, remove the pin that holds the sharp-angle-bend attachment.

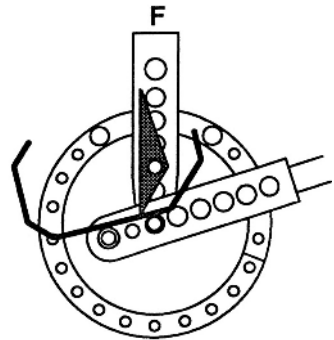
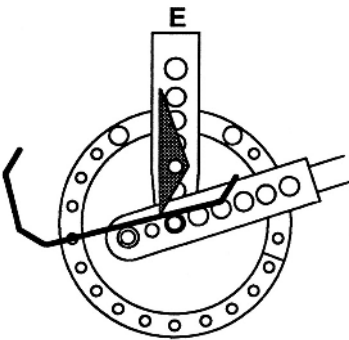
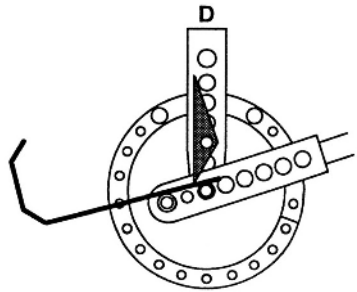
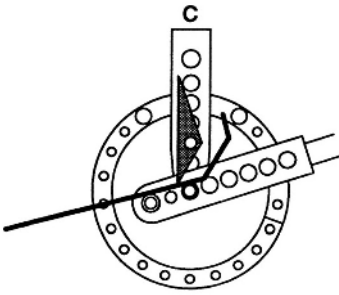

FINISHING

Grind and sand all sharp corners.

LETTER D

Bend sequence

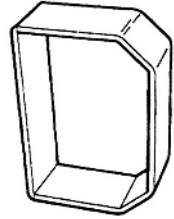
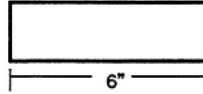
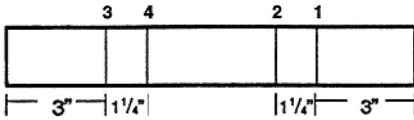

STOCK REQUIRED

- 3/16" stock; 2" max. width
- 1x 12-1/2in blank
- 1 x 6 in blank

SETUP

Make chalk marks on the two 12-7/8" blank as shown on the "Bend Sequence."

BEND NO. 1

Insert the blank into the Bender to the #1 chalk mark (as in A), and bend it to 45°. Re-check the angle before you go on to the second bend.

Chalk-mark the ring, or set a stop, for ease of repeating the 45° bend.

BEND NO. 2

Slide the stock to the #2 chalk mark (as in B), and bend it to 45°. Re-check the angle.

Remove the blank from the Bender. Re-check that the bend leg is at 90° to the front of the "D".

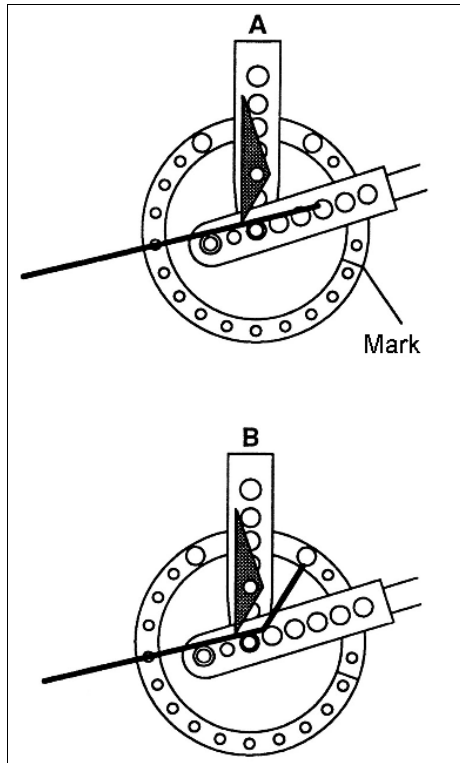

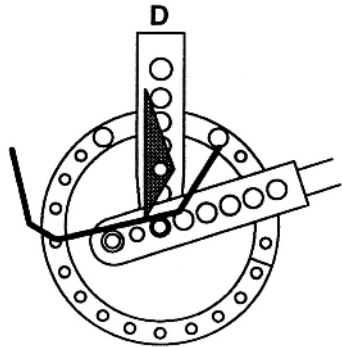
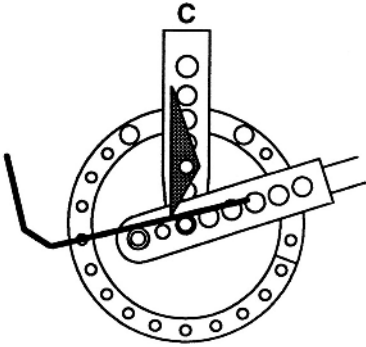

BEND NO. 3

Reverse the stock end-for-end. Slide it to the #3 chalk mark (as in C), and bend it to 45°. Re-check the angle.

BEND NO. 4

Slide the stock to the #4 chalk mark (as in D), and bend it to 45°.

Re-check the angle. Re-check that the two legs are parallel.

To remove the part from the Bender, remove the pin that holds the sharp-angle-bend attachment.

FINISHING

Tack-weld the 6 in. piece to form the back of the letter "D". Grind and sand all sharp corners.

LETTER E

Bend sequence

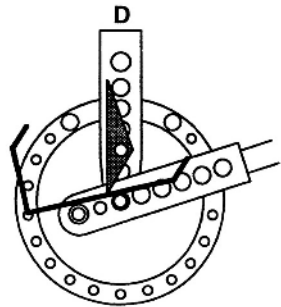
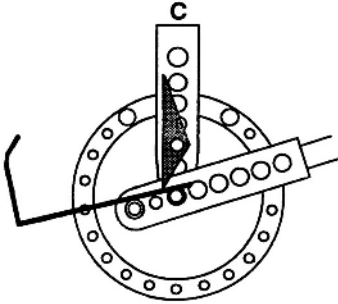
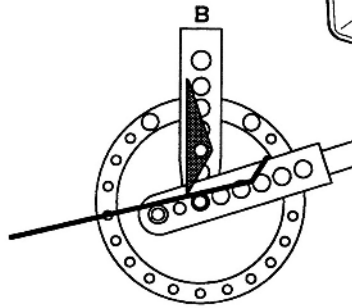
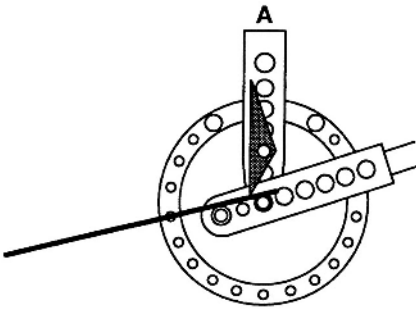
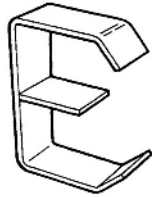
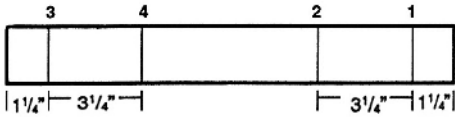

STOCK REQUIRED

- 3/16" stock; 2" max. width
- 1x 14-9/16in blank
- 1 x 2-1/2 in blank

SETUP

Make chalk marks on the 14-9/16" blank as shown on the "Bend Sequence."

BEND NO. 1

Insert the blank into the bender to the #1 chalk mark (as in A), and bend it to 45°. Re-check the angle before you go on to the second bend.

BEND NO. 2

Slide the stock to the #2 chalk mark (as in B), and bend it to 90°. Re-check the angle.

BEND NO. 3

Reverse the stock end-for-end. Slide it to the #3 chalk mark (as in C), and bend it to 45°. Re-check the angle.

BEND NO. 4

Slide the stock to the #4 chalk mark (as in D), and bend it to 90°. Re-check the angle and that the top and bottom of the E are parallel.

To remove the part from the bender, remove the pin that holds the sharp-angle-bend attachment.

FINISHING

Tack-weld the 3-1/2 in insert piece in place between the legs of the "A", parallel to the top edge. Grind and sand all sharp corners.

LETTER F

STOCK REQUIRED

- 3/16" stock; 2" max. width
- 1x 10-3/8in blank
- 1 x 2-1/2 in blank

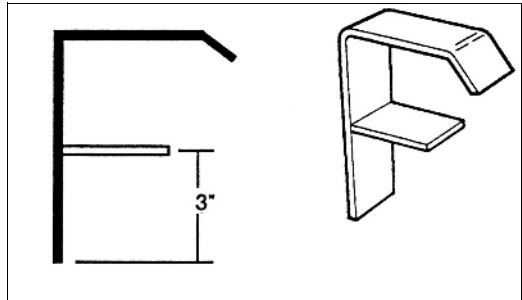

SETUP

Make a letter "L" as shown on page 33.

FINISHING

Position the 2-1/2" piece as shown and tack weld it.

Grind and sand all sharp corners.

LETTER G

STOCK REQUIRED

- 3/16" stock; 2" max. width
- 1 x 14in blank
- 1 x 3 in blank

SETUP

Make a letter "C" as shown on pages 22-25.

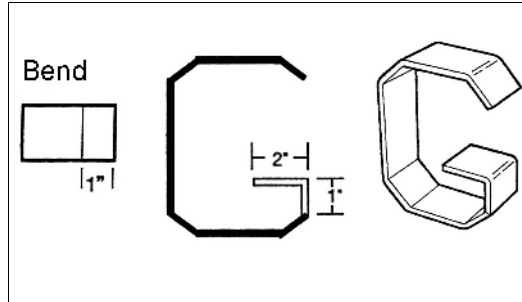

BEND

Insert the 3" blank into the bender to the chalk mark and bend it to 90°. Re-check the angle.

To remove the part from the bender, remove the pin that holds the sharp-angle-bend attachment.

FINISHING

Position the 3" piece as shown and tack-weld it. Grind and sand all sharp corners.

LETTER H

STOCK REQUIRED

- 3/16" stock; 2" max. width
- 2 x 6in blank
- 1 x 3-1/4 in blank

SETUP

None

FINISHING

Tack-weld the pieces together as shown.

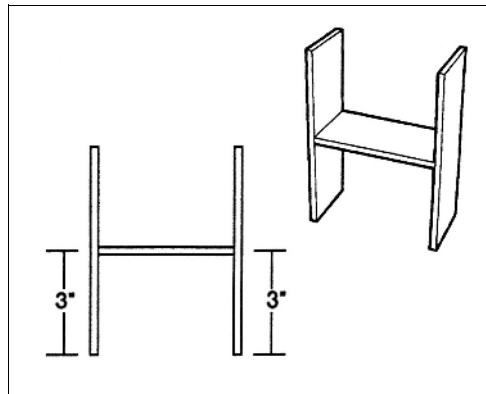

Re-check that the pieces are at 90° to each other. Grind and sand all sharp corners.

LETTER I

STOCK REQUIRED

- 3/16" stock; 2" max. width
- 2 x 5in blank
- 1 x 5-5/8 in blank

SETUP

Make chalk marks on the 5" blanks as shown on the "Bend Sequence."

BEND NO. 1

Insert the blank into the Bender to the #1 chalk mark, and bend it to 45°. Re-check the angle.

Chalk mark the ring, or set a stop, for ease of repeating the 45° bend.

BEND NO. 2

Reverse the stock end-for-end. Slide it to the #2 chalk mark, and bend it to 45°. Re-check the angle.

To remove the part from the Bender, remove the pin that holds the sharp-angle-bend attachment.

FINISHING

Position the 5-5/8" piece between the bent pieces as shown and tack-weld it. Re-check that the parts are 90°.

Grind and sand all sharp corners.

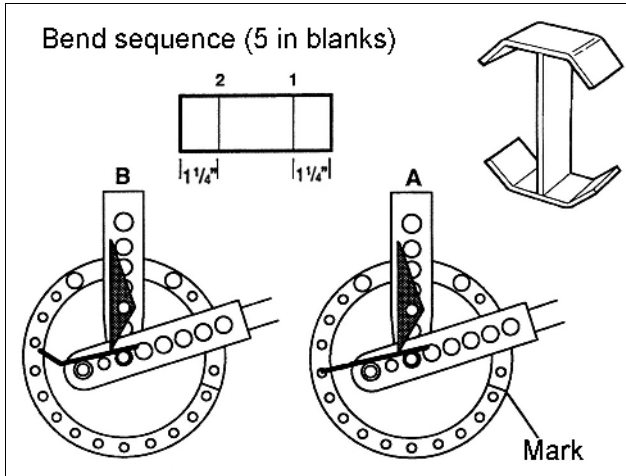

LETTER J

STOCK REQUIRED

- 3/16" stock; 2" max. width
- 1 x 10in blank

SETUP

Make chalk marks on the blanks as shown on the "Bend Sequence."

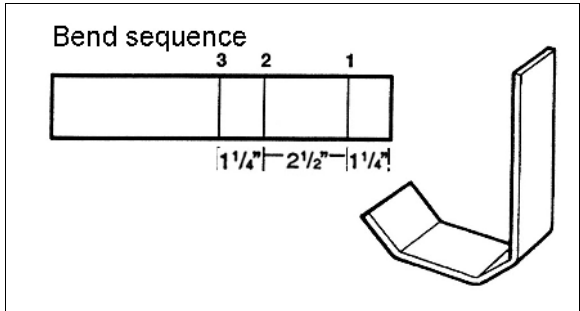

BEND NO. 1

Insert the blank into the bender to the #1 chalk mark, (as in A), and bend it to 45°. Re-check the angle before you go on to the second bend.

Chalk mark the ring, or set a stop, for ease of repeating the 45° bend.

BEND NO. 2

Slide the stock to the #2 chalk mark (as in B), and bend it to 45°. Re-check the angle.

BEND NO. 3

Slide the stock to the #3 chalk mark (as in C), and bend it to 45°. Re-check the angle.

To remove the part from the bender, remove the pin that holds the sharp-angle-bend attachment.

FINISHING

Grind and sand all sharp corners.

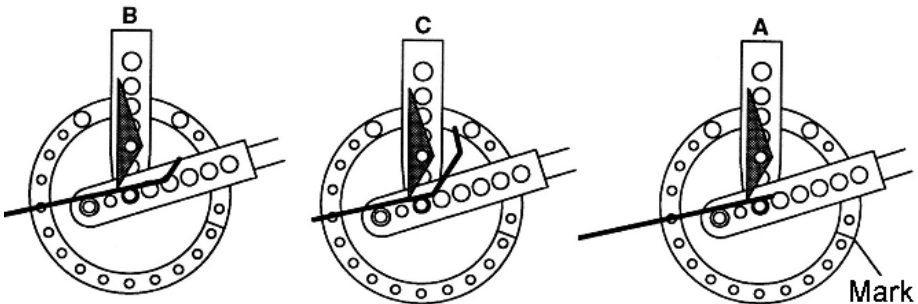

LETTER K

STOCK REQUIRED

- 3/16" stock; 2" max. width
- 1 x 7in blank
- 1 x 6in blank
- 1 x 2-1/2 in blank

SETUP

Make chalk marks on the 7" blanks as shown on the "Bend Sequence."

BEND

Insert the blank into the Bender to the chalk mark, and bend until it measures 6 in. as shown.

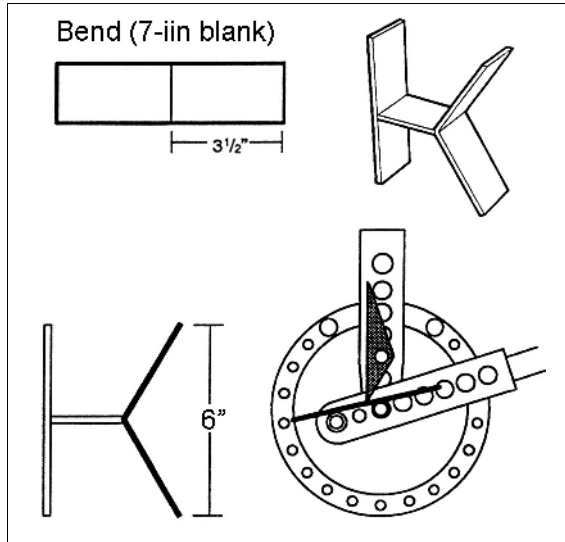

FINISHING

Tack-weld the pieces together as shown.

Re-check that the outer tips of the bent piece are equal distances from the straight piece. Grind and sand all sharp corners.

LETTER L

STOCK REQUIRED

- 3/16" stock; 2" max. width
- 1 x 10-3/8in blank

SETUP

Make chalk marks on the blanks as shown on the "Bend Sequence."

BEND NO. 1

Insert the blank into the Bender to the #1 chalk mark, and bend it to 45°. Re-check the angle.

BEND NO. 2

Slide the stock to the #2 chalk mark, and bend to 90°. Re-check the angle. To remove the part from the bender, remove the pin that holds the sharp-angle-bend attachment.

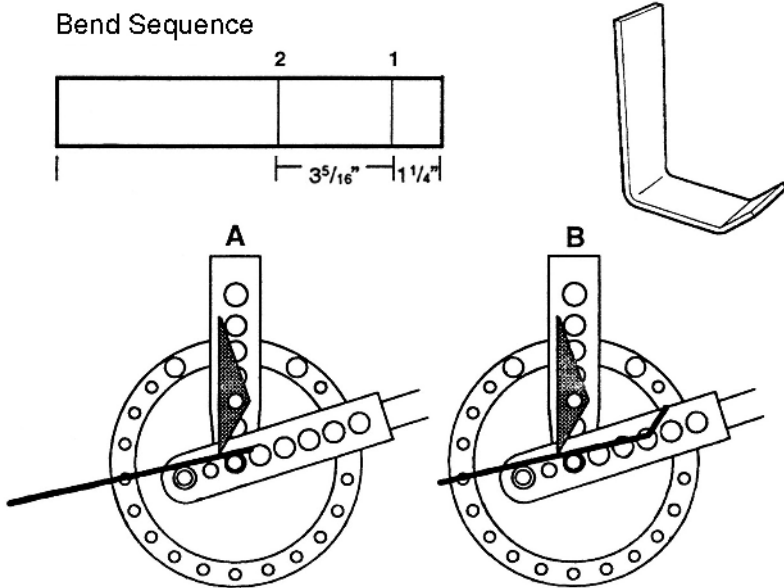

FINISHING

Grind and sand all sharp corners.

LETTER M

STOCK REQUIRED:

- 3/16" STOCK; 2" max width
- 2 X 13-1/2" Blanks

SETUP

Make two letter "v"s as shown on page 42.

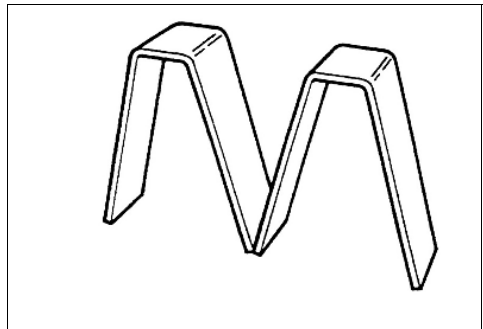

FINISHING

Turn the "V"s upside down and tack weld them together as shown. Check that the three bottom tips are aligned.

Grind and sand all sharp corners.

LETTER N

Bend Sequence (8-1/16" blank)

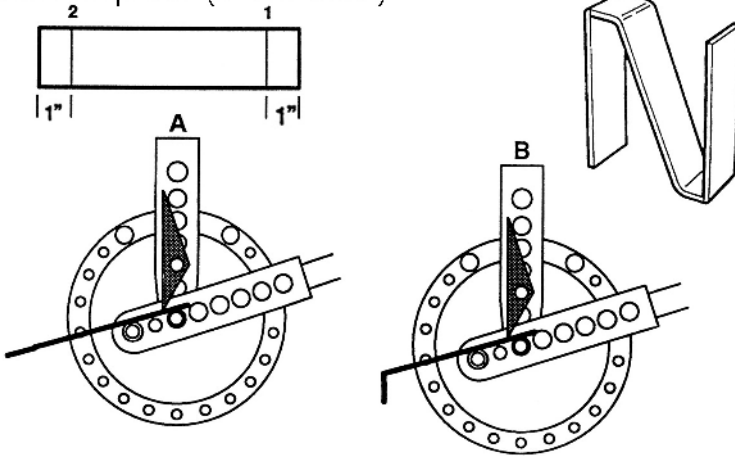

STOCK REQUIRED:

- 3/16" STOCK; 2" max width
- 1 X 8-1/16" blank
- 2 x 6 in blanks

SETUP

Make chalk marks on the 8-1/16" blanks as shown on the "Bend Sequence."

BEND NO. 1

Insert the blank into the Bender to the #1 chalk mark, (as in A), and bend it to 73°. Re-check the angle.

BEND NO. 2

Reverse the stock end-for-end. Slide it to the #2 chalk mark, and bend it to 73°. Re-check the angle.

To remove the part from the bender, remove the pin that holds the sharp-angle-bend attachment.

FINISHING

Tack-weld the pieces together. Re-check that the straight legs are parallel. Grind and sand all sharp corners.

LETTER O

STOCK REQUIRED:

- 3/16" STOCK; 2" MAX WIDTH
- 1 X 14" Blank
- 1 x 3-7/8" Blank

SETUP

Make a letter "C" from the 14" blank as shown on page 17.

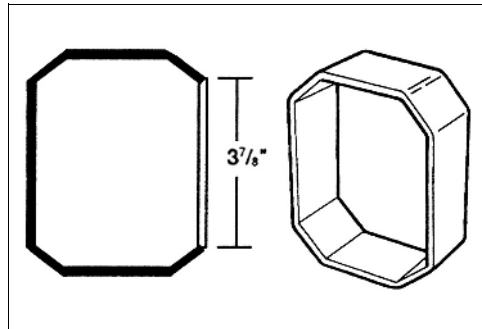

FINISHING

Tack-weld the two pieces together as shown. Grind and sand all sharp corners.

LETTER P

STOCK REQUIRED:

- 3/16" STOCK; 2" MAX WIDTH
- 1 X 8-7/8" Blank
- 1 x 6" Blank

SETUP

Make part of a letter "B" (page 16)—the straight piece and one loop.

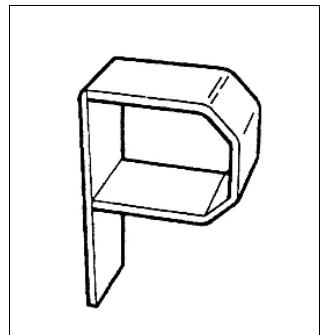

FINISHING

Tack-weld the pieces together. Grind and sand all sharp corners.

LETTER Q

STOCK REQUIRED:

- 3/16" STOCK; 2" MAX WIDTH
- 1 X 14" Blank
- 1 x 3-7/8" Blank
- 1 x 2" Blank
- 1 x 3/4" Blank

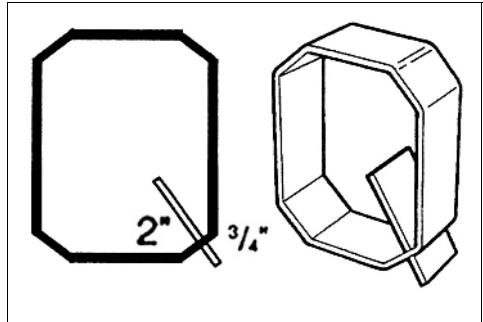

SETUP

Make a letter "O" (above).

FINISHING

Tack-weld the short pieces to the "O" as shown above. Grind and sand all sharp corners.

LETTER R

STOCK REQUIRED:

- 3/16" STOCK; 2" MAX WIDTH
- 1 X 8-7/8" Blank
- 1 x 6" Blank
- 1 x 3-1/8" Blank

SETUP

Make part of a letter "P" (page 26).

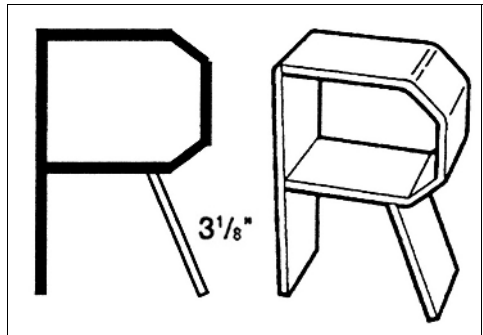

FINISHING

Tack-weld the 3-1/8" piece to the "P" as shown.

Grind and sand all sharp corners.

LETTER S

Bend Sequence

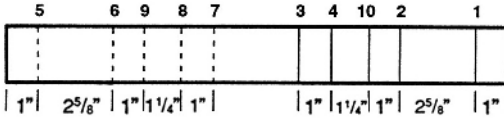

STOCK REQUIRED:

- 3/16" STOCK; 2" MAX WIDTH
- 1 X 16-1/2" Blank

SETUP

Make chalk marks on the blank as shown on the "Bend Sequence." Note that the five chalk marks on one end of the blank must be on the opposite face from the five marks on the other end.

BEND NO. 1

Insert the blank into the Bender to the #1 chalk mark (as in A), and bend it to 45°. Re-check the angle.

Chalk-mark the ring, or set a stop, for ease of repeating the 45° bend. (Note that Bends #3 and #7 are to 41°.)

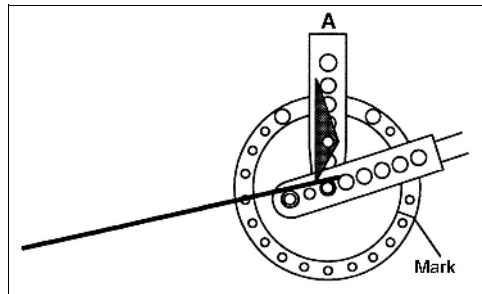

BEND NO. 2

Slide the blank to the #2 chalk mark (as in B), and bend it to 45°.

CAUTION: Because of the number of bends, it is especially important to check all bend angles carefully when making the letter "S."

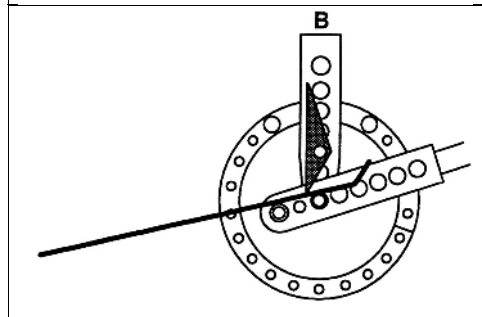

BEND NO. 3

Slide the blank to the #3 chalk mark (as in C), and bend it to 41°. Re-check the angle.

BEND NO. 4

Slide the blank back to the #4 chalk mark (as in D), and bend it to 45°.

BEND NO. 5

Reverse the stock end-for-end. Slide the blank to the #5 chalk mark (as in E), and bend it to 45°. Re-check the angle.

BEND NO. 6

Slide the blank back to the #6 chalk mark (as in F), and bend it to 45°. Re-check the angle.

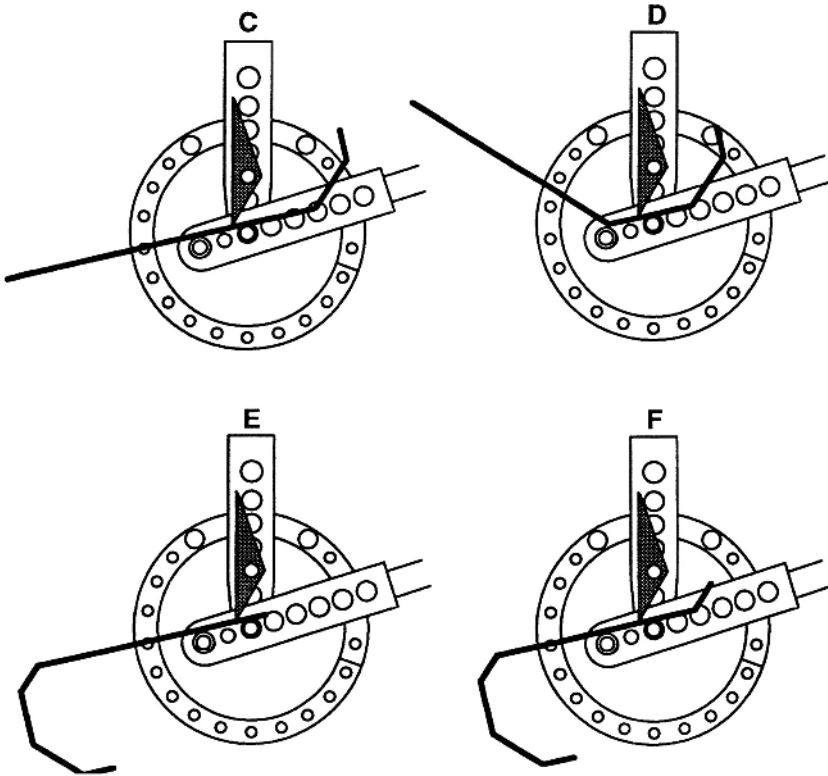

BEND NO. 7

Slide the blank to the #7 chalk mark (as in G), and bend it to 41°. Re-check the angle.

BEND NO. 8

Slide the blank back to the #8 chalk mark (as in H), and bend it to 45°. Re-check the angle.

BEND NO. 9

Reverse the stock end-for-end. Pull the pin in the sharp-angle-bend attachment to allow space for the blank. Insert the blank, and reinstall the pin.

Slide the blank to the #9 chalk mark (as in I), and bend it to 45°. Re-check the angle.

BEND NO. 10

Again reverse the stock end-for-end. Slide the blank to the #10 chalk mark (as in J), and bend it to 45°. Re-check the angle, and check that the top and bottom of the "S" are parallel.

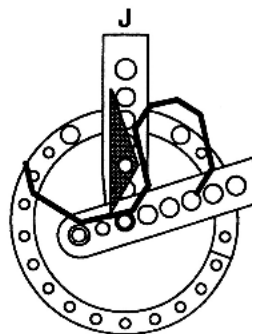
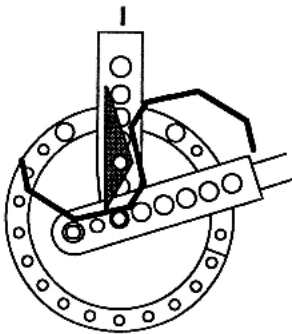
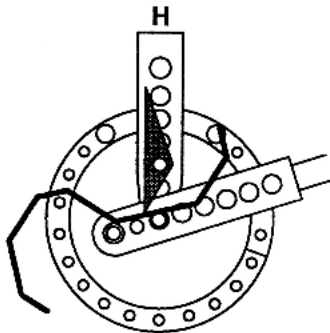
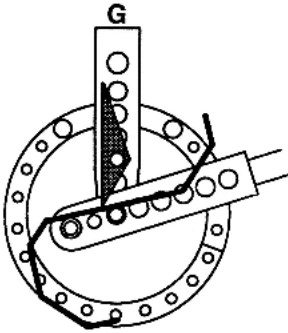

LETTER T

Bend sequence (5-13/16" blank)

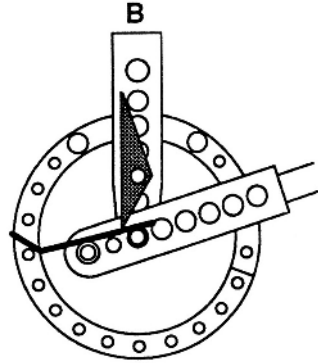
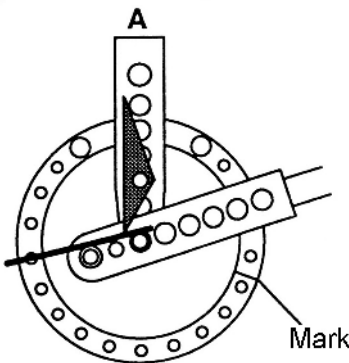
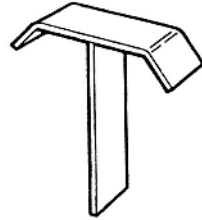
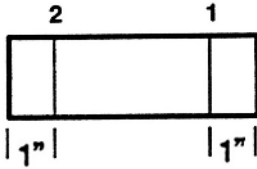

STOCK REQUIRED:

- 3/16" STOCK; 2" MAX WIDTH
- 1 X 6" Blank
- 1 x 5-1/16 blank

SETUP

Make chalk marks on the 5-13/16" blank as shown on the "Bend Sequence."

BEND NO. 1

Insert the blank into the bender to the #1 chalk mark (as in A), and bend it to 45°. Re-check the angle.

Chalk mark the ring, or set a stop, for ease of repeating the 45° bend.

BEND NO. 2

Reverse the stock end-for-end. Slide it to the #2 chalk mark (as in B), and bend it to 45°. Re-check the angle.

FINISHING

Grind and sand all sharp corners.

LETTER U

Bend sequence

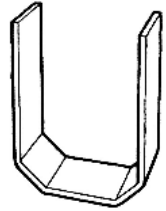
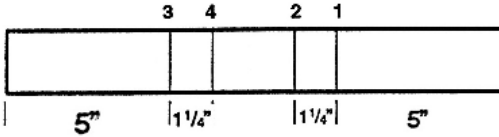

STOCK REQUIRED:

- 3/16" STOCK; 2" MAX WIDTH
- 1 X 14-3/4" Blank

SETUP-U

Make chalk marks on the blank as shown on the "Bend Sequence."

BEND NO. 1

Insert the blank into the bender to the #1 chalk mark, (as in A), and bend it to 45°. Re-check the angle.

Chalk-mark the ring, or set a stop, for ease of repeating the 45° bend.

BEND NO. 2

Slide the blank to the #2 chalk mark (as in B), and bend it to 45°. Re-check the angle.

BEND NO. 3

Reverse the stock end-for-end. Slide it to the #3 chalk mark (as in C), and bend it to 45°. Re-check the angle.

BEND NO. 4

Slide the stock to the #4 chalk mark (as in D), and bend it to 45°. Re-check the angle, and check that the legs of the "U" are parallel.

FINISHING

Grind and sand all sharp corners.

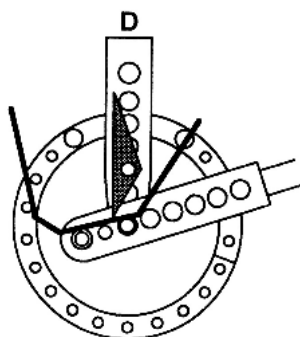
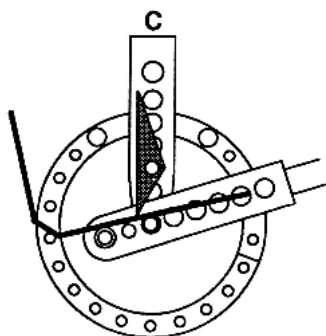
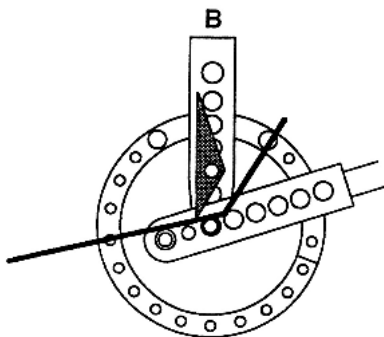
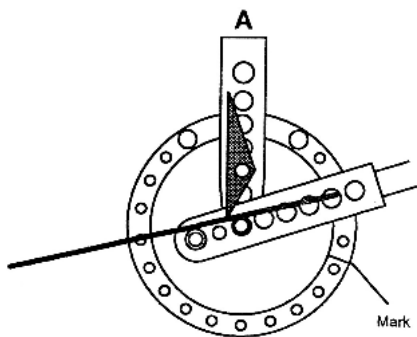

LETTER V

Bend sequence

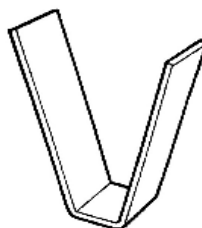
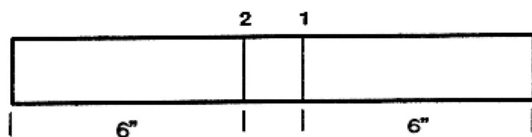

STOCK REQUIRED:

- 3/16" STOCK; 2" MAX WIDTH
- 1 X 13-1/2" Blank

SETUP

Make chalk marks on the 5-13/16-in. blank as shown on the "Bend Sequence."

BEND NO. 1

Insert the blank into the bender to the #1 chalk mark (as in A), and bend it to 75°.

BEND NO. 2

Slide the blank to the #2 chalk mark (as in B), and bend it to 75°. To remove the part, pull the pin in the sharp-angle-bend attachment.

FINISHING

Grind and sand all sharp corners.

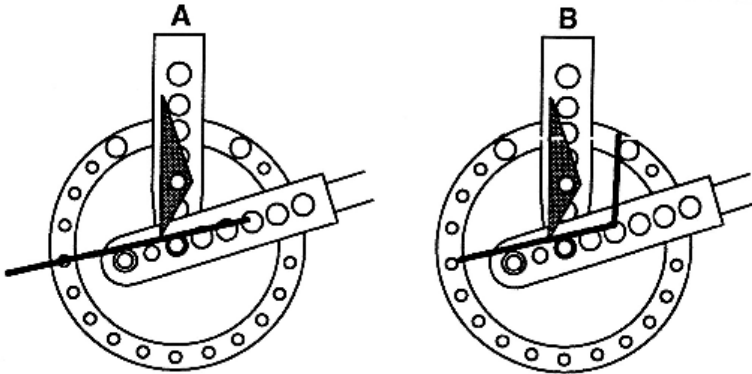

LETTER W

STOCK REQUIRED:

- 3/16" STOCK; 2" MAX WIDTH
- 2 x 13-1/2" Blanks

Make the letter "W" by tack-welding together two letter "V"s (the same as a letter "M", page 33).

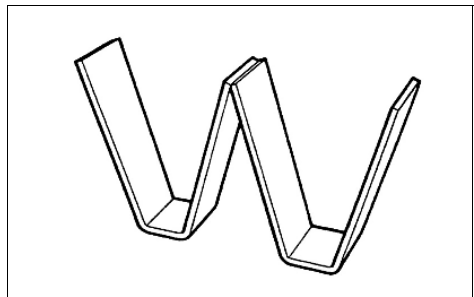

LETTER X

Bend

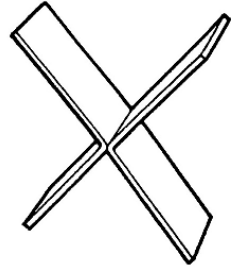
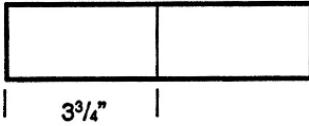

STOCK REQUIRED:

- 3/16" STOCK; 2" MAX WIDTH
- 2 x 7-1/2" Blanks

SETUP

Make chalk marks on the blank as shown on the "Bend Sequence."

BEND

Insert the blank into the Bender to the chalk mark, and bend it until the outside dimension is 6 in. (as shown).

FINISHING

Tack-weld the two pieces together. Check that the parts are parallel. Grind and sand all sharp corners.

LETTER Y

BEND SEQUENCE (9 1/2-in. blank)

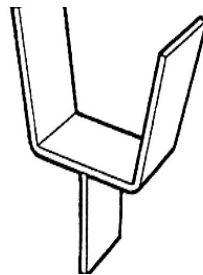
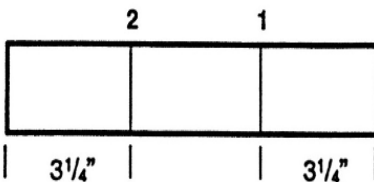

STOCK REQUIRED:

- 3/16" STOCK; 2" MAX WIDTH

- 1 x 9-1/2" Blank
- 1 x 3-3/4" Blank

SETUP

Make chalk marks on the blank as shown on the "Bend Sequence."

BEND NO. 1

Insert the blank into the Bender to the #1 chalk mark (as in A), and bend it to 80°. Re-check the angle.

BEND NO. 2

Slide the stock to the #2 chalk mark (as in B), and bend it to 80°. Re-check the angle.

To remove the part, pull the pin from the sharp-angle-bend attachment.

FINISHING

Grind and sand all sharp corners.

LETTER Z

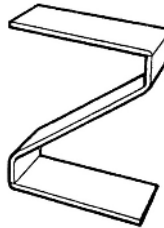
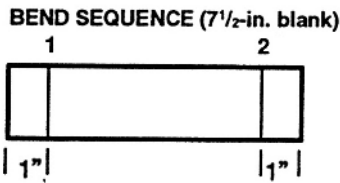

STOCK REQUIRED:

- 3/16" STOCK; 2" MAX WIDTH
- 2 x 7-1/2" Blanks

SETUP

Make chalk marks on the 7-1/2" blank as shown on the "Bend Sequence."

BEND NO. 1

Insert the blank into the Bender to the #1 chalk mark (as in A), and bend it to 50°. Re-check the angle.

BEND NO. 2

Reverse the part end-for-end. Slide it to the #2 chalk mark (as in B), and bend it to 50°.

FINISHING

Tack-weld the bent piece to the two 4-1/2" pieces. The legs of the "Z" should be parallel, 6" apart. Grind and sand all sharp corners.

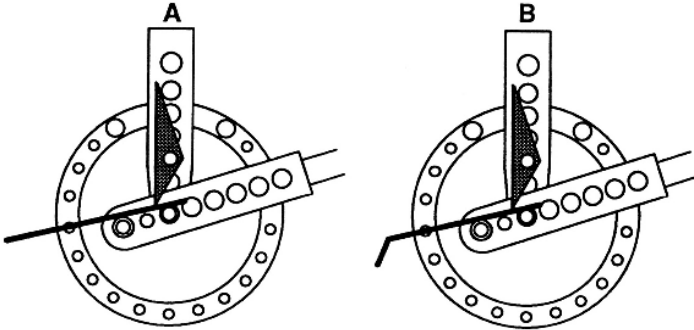

COMPONENT PARTS

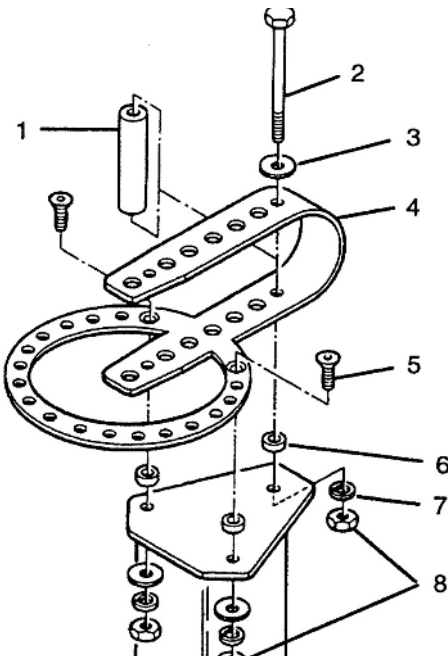

	Description
1	Spacer, loop
2	Bolt, $\frac{3}{8}$ x 4 $\frac{1}{8}$ in
3	Washer, flat, $\frac{3}{8}$
4	Ring Assembly
5	Bolt, flat-head $\frac{3}{8}$ in
6	Spacer, ring
7	Lockwasher $\frac{3}{8}$ in
8	Nut $\frac{3}{8}$ in

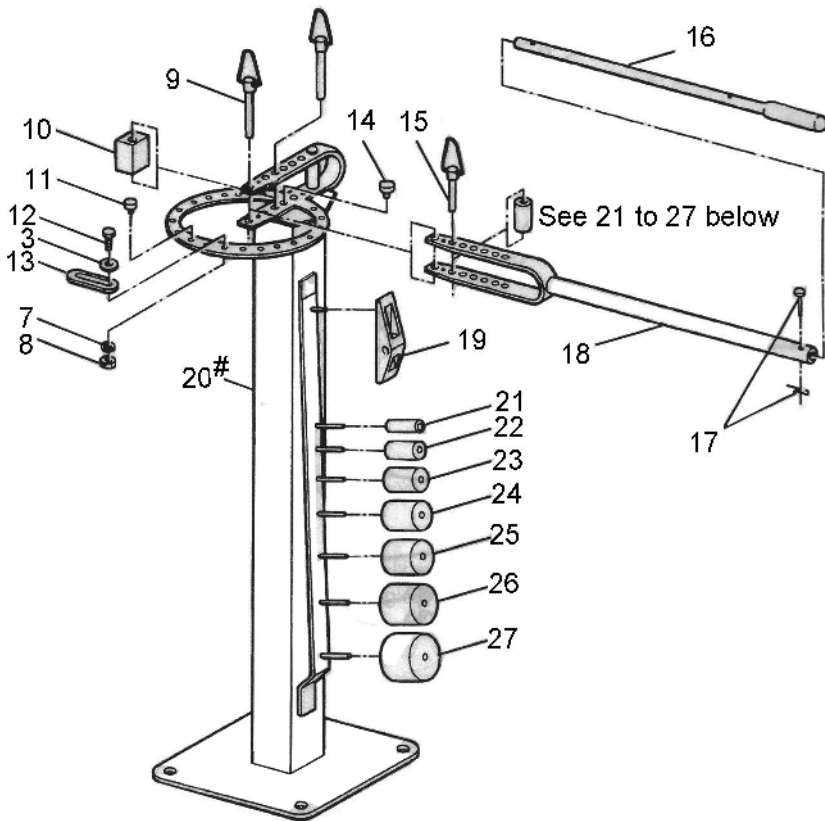

ITEM	DESCRIPTION
9	Hich Pin - long
10	Stop Block
11	Support block
12	Bolt, $\frac{3}{8}$ x $1\frac{1}{8}$ in
13	Adjustable stop
14	Fixed stop
15	Hitch Pin-short
16	Handle extension
17	Pin with clip
18	Handle

ITEM	DESCRIPTION
19	Sharp angle bend attachment
20#	Stand (CCB1B)
20#	Stand (CCB2B)
21	Die - 1-in
22	Die - $1\frac{1}{4}$ -in
23	Die - $1\frac{1}{2}$ -in
24	Die - $1\frac{3}{4}$ -in
25	Die - 2-in
26	Die - $2\frac{1}{2}$ -in
27	Die - 3-in

A SELECTION FROM THE VAST RANGE OF

Clarke[®]

QUALITY PRODUCTS



AIR COMPRESSORS

From DIY to industrial, Plus air tools, spray guns and accessories.

GENERATORS

Prime duty or emergency standby for business, home and leisure.

POWER WASHERS

Hot and cold, electric and engine driven - we have what you need

WELDERS

Mig, Arc, Tig and Spot. From DIY to auto/industrial.

METALWORKING

Drills, grinders and saws for DIY and professional use.

WOODWORKING

Saws, sanders, lathes, mortisers and dust extraction.

HYDRAULICS

Cranes, body repair kits, transmission jacks for all types of workshop use.

WATER PUMPS

Submersible, electric and engine driven for DIY, agriculture and industry.

POWERTOOLS

Angle grinders, cordless drill sets, saws and sanders.

STARTERS/CHARGERS

All sizes for car and commercial use.

**PARTS & SERVICE:
0208 988 7400**

Parts Enquiries
Parts@clarkeinternational.com

Servicing & Technical Enquiries
Service@clarkeinternational.com

SALES: UK 01992 565333 or Export 00 44 (0)1992 565335

Clarke[®] INTERNATIONAL Hemnall Street, Epping, Essex CM16 4LG
www.clarkeinternational.com